

THIS DRAWING IS UNPUBLISHED. RELEASED FOR PUBLICATION ,19 .
 © COPYRIGHT 19 BY AMP INCORPORATED. ALL RIGHTS RESERVED.

LOC		DIST		REVISIONS			
P	LTR	DESCRIPTION		DATE	DWN	APVD	
AF	50	F		REV PER 0G3A-0050-02	06FEB02	JR	PD

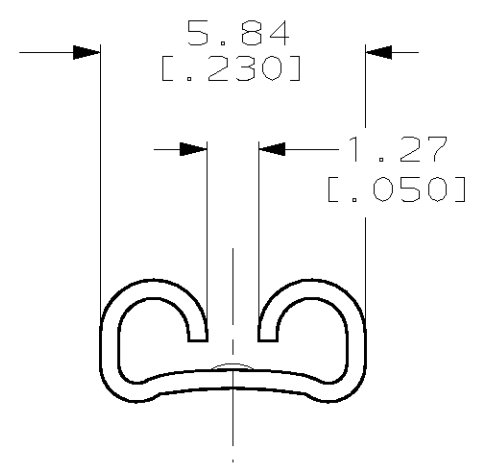
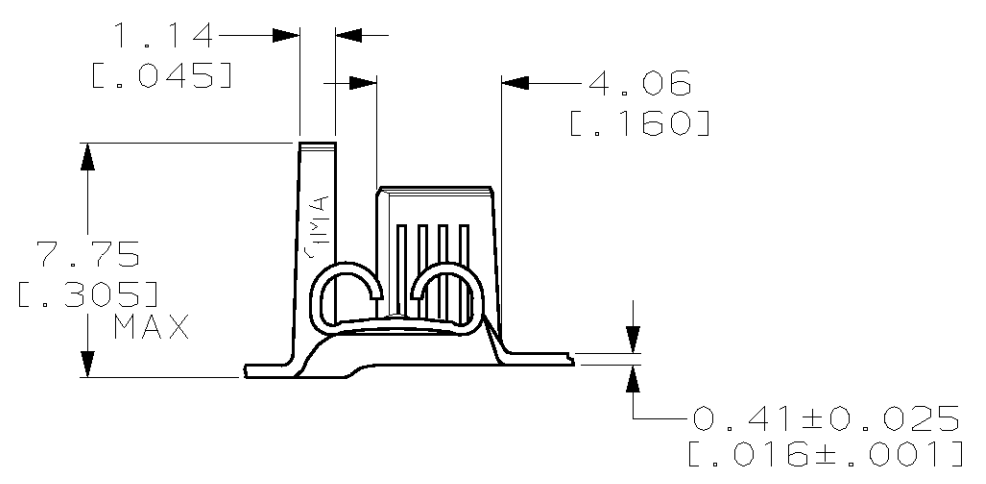
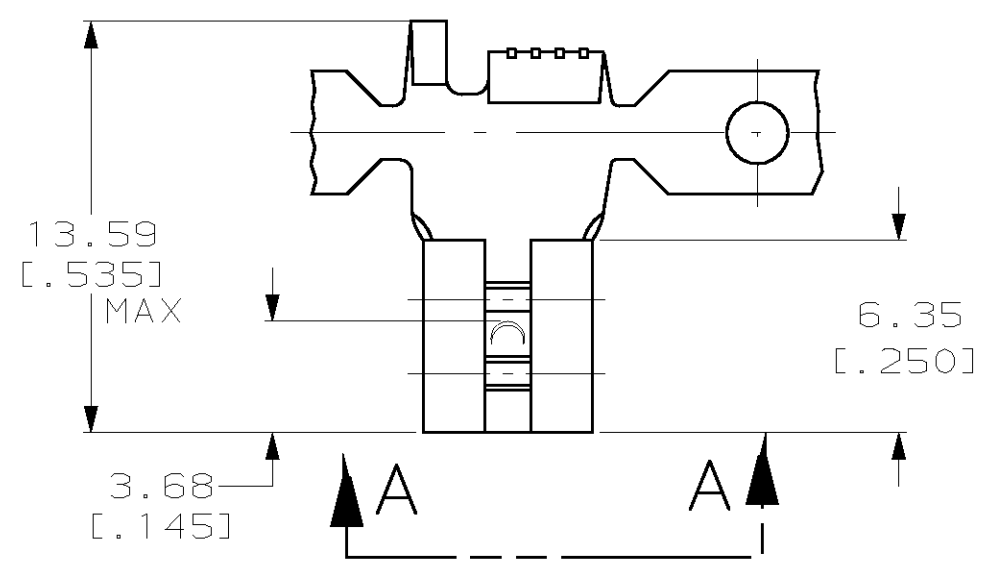

VIEW A-A
SCALE 6:1

- 1 CONTINUOUS STRIP ON REELS.
- 2 FEED IS 16.51±0.076 [.650±.005].
- 3 ACCEPTS WIRE SIZE [#18-#14] AWG.
- 4 INSULATION RANGE TO BE 1.90-3.94 [.075-.155] DIA.
- 5 MATING TAB THK TO BE 0.813±0.025 [.032±.001].

0.002032 [.000080] MIN TIN	1217527-2
-	1217527-1
FINISH	PART NO.

THIS DRAWING IS A CONTROLLED DOCUMENT FOR AMP INCORPORATED. IT IS SUBJECT TO CHANGE AND THE CONTROLLING ENGINEERING ORGANIZATION SHOULD BE CONTACTED FOR THE LATEST REVISION.		DWN JR RUTH 03NOV00	AMP Incorporated Harrisburg, PA 17105-3608	
DIMENSIONS: MM [INCHES]	TOLERANCES UNLESS OTHERWISE SPECIFIED:	CHK MS FEHER 03NOV00	NAME RECEPTACLE, FASTON, FLAG, 4.75 [.187] SERIES	
	0 PLC ±-	APVD P DESANTIS 03NOV00	PRODUCT SPEC	SIZE A3
	1 PLC ±-	PRODUCT SPEC	APPLICATION SPEC	CAGE CODE 00779
MATERIAL T3 PHOS BRONZE	FINISH SEE TABLE	WEIGHT -	114-2155	DRAWING NO C-1217527
CUSTOMER DRAWING			SCALE 4:1	SHEET 1 OF 1
			REV F	